

CHANGE IMPACT AND RISK ANALYSIS (CIRA) –

COMBINING THE CPM/PDD THEORY AND FMEA-METHODOLOGY FOR AN IMPROVED ENGINEERING CHANGE MANAGEMENT

Jan Conrad¹, Till Deubel¹, Christian Köhler¹, Sören Wanke¹ and Christian Weber²

¹ Saarland University, Institute of Engineering Design/CAD, Saarbrücken, Germany

² TU Ilmenau, Engineering Design, Ilmenau, Germany

ABSTRACT

The change process is one of the most critical tasks of the product development process. Misinterpretation or lack of knowledge about impacts or risks of changes can cause serious disadvantages to companies, e.g. high failure or change costs or image losses caused by products with a quality that is unacceptable. Supervising the change process is a challenging task; an important part of this task is the analysis and assessment of risks and impacts of changes. This contribution presents an approach to support the process of analysing and assessing the effects of changes in the product development process. The approach is based on two methods: First on the CPM/PDD theory developed at the Institute of Engineering Design/CAD in order to synthesise potential solutions to change requests and to analyse their impacts; second on the common Failure Modes and Effects Analysis (FMEA)-method in order to assess the risks and impacts of changes and to document the analysis.

Keywords: CIRA, CPM/PDD, Design for Quality, Engineering Change Management, FMEA, Risk Management

1 INTRODUCTION

Despite the fact that the number of companies introducing and maintaining certified Quality Management Systems (QMS) has been constantly growing, more and more reports about quality problems, defective products and product call-backs are encountered [1]. According to a study from PriceWaterhouseCoopers [2], the number of product recalls in the EU has more than doubled within the year 2005 (from six average call-backs per week in 2004 to 14 in 2005). This alarming number motivates further research to discover the reasons and to find means to avoid quality problems.

One fact in that context is that QMS force companies not only to improve their products and processes but also to establish effective failure management systems. Subsequently, more failures in products and processes can be found now [1]. Partly, these failures are detected within the walls of the factory, some of them, however, only after the delivery of a product, which causes product recalls.

Still, failures occur and there must be reasons why. Possible explanations therefore could be:

- The use of inadequate and insufficient tools or methods within the QMS.
- The tools or methods in use are not integrated deeply enough in the processes.
- The tools or methods in use are applied in an inadequate or wrong way.
- The tools or methods (or even the QMS itself) are not accepted and supported by the company's staff.
- There are still processes or process steps that are susceptible to failures.

The first four points are interdependent: Certainly, there is a huge number of approved and applied quality management tools, e.g. Quality Function Deployment (QFD) [3], Failure Modes and Effects Analysis (FMEA, [4], [5]), Fault Tree Analysis (FTA, [4]) etc. Probably, there are even too many re-

lated methods that prevent their actual use in the processes. For example, a large German automotive supplier uses the FMEA and two other methods to do the same thing – looking for failures and their causes. This shows that even the FMEA – probably the quality method which is most widely spread – is not integrated deeply enough in manufacturing as well as design processes. If people are not used to a method, they make mistakes when applying a method, do not accept the method [6] or get confused by it.

The last point shows the possibility that certain processes or process steps are susceptible to failures. One famous, often risky, activity – even if its intention is the correction of mistakes or the improvement of products – is the change process in product or production process development [7].

This contribution presents an approach to analyse and assess the risks and impacts of changes in product and process development by transferring the well-known FMEA-methodology to the change process and combining it with the Characteristics-Properties Modelling/Property-Driven Development (CPM/PDD) theory.

Section 2 introduces the topic of engineering change management, distinguishes between the terms change management and engineering change management and outlines the engineering change process which is the basis of the approach described later. Section 3 gives a short introduction to the Characteristics-Properties Modelling/Property-Driven Development approach. Sections 4 and 5 present the developed Change Impact and Risk Analysis (CIRA) method and a case study. This contribution finishes with section 6 which provides a critical evaluation of the CIRA approach, some conclusions and proposals for future work.

2 ENGINEERING CHANGE MANAGEMENT

It is well-known that markets follow customers' requirements. Today's customers prefer individualised products more and more [8]. This trend leads to a diversification and fragmentation of markets and to a rising variety of products with smaller production runs and shorter product life cycles [9]. Additionally, the globalisation of the markets results in a harder competition between the rivals with high-quality products at lower sales-prices [10]. In order to meet the market requirements, existing products have to be constantly improved or updated and new products have to be introduced rapidly [9]. Therefore, changes in products, concepts and solutions are necessary and the management of changes becomes more important.

An overview of research activities in Engineering Change Management is given in [11].

2.1 Change Management versus Engineering Change Management

Jarratt et al. state in [9] that the often used term *change management* "... refers to the administration and supervision of corporate or organisational transformation, be it the results of merging two firms or implementing a new business process." This statement is supported by a number of authors, e.g. by Krüger [12], who writes that change management is the active management of change processes and includes all tasks, processes, institutions and tools of company related changes and deployments. Both statements refer to changes in (business) processes and not to changes in products, which are the focus of this examination. Because of that, [9] strictly distinguishes between the terms *change management* and *engineering change (management)* stating that *engineering change management* "... refers to the organisation and control of the process of making alterations to products." This contribution focuses on engineering change management (ECM).

There are two main reasons for an engineering change (EC). The first one is the elimination of a product's error or "flaw" [13], [14] and the second is the improvement, enhancement or adaptation of a product. Especially the first issue can have negative impacts on a product development project, e.g. slipping schedules or overrunning budgets [9].

2.2 The generic Engineering Change Process (ECP)

In [9], a six-phase generic engineering change process (ECP) is introduced that gets its ignition from the so-called change trigger. An ECP can either be initiated by the product itself (i.e. by errors) or from outside (e.g. by customer requests) [9].

In the first phase a well-founded change request must be raised. That is followed by the identification of potential solutions to the engineering change request (ECR), phase two, and the assessment of impacts and risks of the implementation of the ECR-solutions, phase three. Phase four includes the selection and approval of a solution by an engineering change board. The approved solution then gets

implemented in phase five. Finally, after a certain period of time, the change should be reviewed in order to check whether the change was successful or not and what lessons can be learnt out of the change, phase 6. The generic ECP is illustrated in Figure 1.

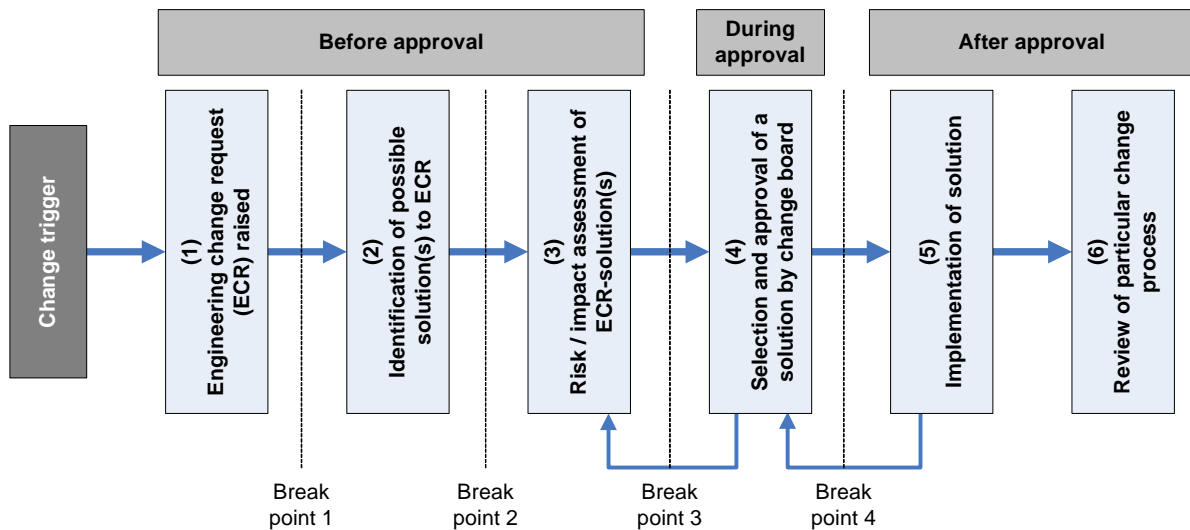

Figure 1: The generic engineering change process (following [9])

In Figure 1 four break points are shown. The intention of these break points is to stop the ECP there if necessary. For example, the ECP would be stopped at break point 3 if the risk/impact assessment of phase 3 came to the result, that the proposed solutions were too risky for the company. This contribution focuses on the second and the third phase of the ECP.

3 THE CHARACTERISTICS-PROPERTIES MODELLING (CPM) AND PROPERTY-DRIVEN DEVELOPMENT (PDD) APPROACH

This section presents a very short overview of the CPM/PDD theory used in product development to model products and the product development process. Core of the CPM/PDD theory is a clear distinction between characteristics and properties:

- *Characteristics* (C_m) describe the shape and the structure of a product, e.g. geometry, BOM, materials etc.
Characteristics can be directly established, assigned and modified by the designer.
- *Properties* (P_n) describe the behaviour of a product, e.g. weight, manufacturability, function, cost, user friendliness etc.
Properties can not be directly established by the designer; they can only be indirectly influenced by changing the depending characteristics.

The interrelations between characteristics and properties are modelled by *relations* (R_n). Characteristics, relations and properties can be depicted in a network-like structure (see Figure 2). Exactly this network-like structure is the formal description needed to evaluate the effects caused by the change of an element.

There are two types of relations between characteristics and properties: *Synthesis* which, based on given/required properties aims at establishing or assigning appropriate product characteristics, and *analysis* which, based on known/given characteristics of a product, determines its properties.

In this approach product development is seen as a sequence of synthesis and analysis steps where in each analysis step one or more property “values”¹ are compared with the required properties. The difference between the existing and the required properties indicates which properties have to be customised by modifying the related characteristics, thus controlling the process.

¹ It is not always possible to measure a property by a countable value, e.g. the haptic of a surface.

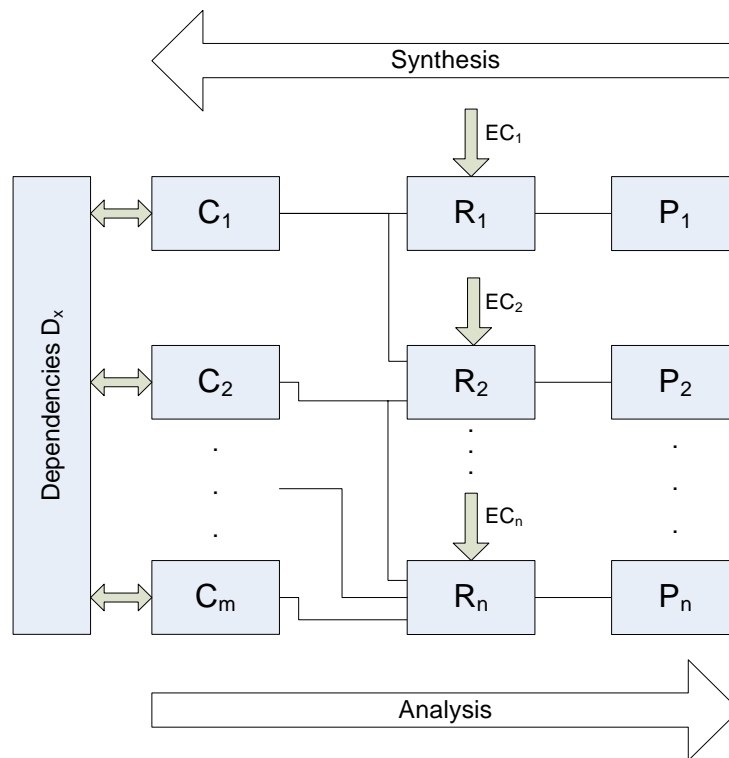

Figure 2: The CPM/PDD-model

There could be internal relations between characteristics, the *dependencies* D_x and *external conditions* EC_n . A very simple example for a dependency is that the external diameter of a shaft has to be equal to the internal diameter of the corresponding hub.

For more detailed descriptions of the CPM/PDD theory see also [15], [16], [17], [18], [19] or [20]. [15] describes also the applicability of the CPM/PDD theory for the planning of manufacturing systems.

4 COMBINATION OF CPM/PDD AND FMEA-METHODOLOGY FOR AN IMPROVED ENGINEERING CHANGE MANAGEMENT

The aim of this section is to provide a new method to analyse and assess the risks and impacts of possible solutions of an engineering change request. This new approach is based on the CPM/PDD theory and combines it with a familiar FMEA-like method. For this, we have to define what an engineering change request is in the context of CPM/PDD, how the phases 2 and 3 of the ECP can be represented in the new approach and what a possible solution to a change request is.

In order to keep this contribution comprehensible, a few simplifications and assumptions are made: It is assumed, that a complete CPM product structure already exists, i.e. the product has been developed based on PDD, and that the required and achieved properties fit together.

4.1 Engineering Change Request represented in CPM/PDD

The first thing to describe is how a change request in the CPM/PDD theory can look like. Principally, in CPM/PDD five elements exist that are able to trigger an engineering change:

- A change of one or more characteristics, e.g. a modification of the diameter of a shaft
- A change of one or more required properties, e.g. the change of customer desires
- A change of external conditions, e.g. new standards
- A change of internal dependencies, e.g. the realisation of a different solution
- A change of relations between characteristics and properties, e.g. the use of a different formula, tool or practical experiences from the field

This contribution focuses on change requests related to the change of required properties, because this is the most frequent one.

4.2 Analysis and Assessment of Risks and Impacts of Change Request Solutions “CHANGE IMPACT AND RISK ANALYSIS (CIRA)”

Probably, the most-common method used to analyse and assess risks is the Failure Modes and Effects Analysis (FMEA). The whole FMEA approach is based on two main questions:

- What happens if ...?
- How to discover or prevent the negative effects?²

Exactly, these two questions are needed to give an answer to the third phase of the generic engineering change process (illustrated in Figure 1). Translated to the CPM/PDD representation of the ECP the first question means: “What happens if a required property is changed?” The second question is: “How to discover unintentional side effects and how to prevent further changes?” Thus, the application of these two questions should lead to the selection of the solution with the lowest risk and the fewest (side) impacts on the rest of the product or process. Thereby, the Change Impact and Risk Analysis (CIRA) gives a recommendation for the phase four of the ECP.

The CIRA method is subdivided in six steps that are described in the following subsections:

- Structuring
- Relevance classification
- Solution synthesis
- Impact analysis
- Risk evaluation
- Safeguarding

The first five phases of CIRA are supported by the form depicted in Figure 3. The intention of the form is to support the analysis and to document the results.

CHANGE IMPACT AND RISK ANALYSIS (CIRA)									
		Product: _____						Date: _____	
		Product-ID: _____						Dep.: _____	
EC-request: _____						ECR-No.: _____			
As critically identified properties	Property relevance	Adjustable characteristics	Potential ECR-solution	Impact on other properties characteristics		S	C	I	Change classification number (CCN)
(1)	(2)	(3)	(4)	(5)	(6)	(7)	(8)	(9)	(10)

Figure 3: CIRA form proposal

4.2.1 Structuring

The first phase of CIRA gives the structure to the analysis. The header of the CIRA form is filled out and the engineering change request is described. In order to start the analysis, all the properties identified as critical are listed in column (1) of the CIRA form. The critical properties are identified via the CPM/PDD model.

As assumed before, the raised engineering change request is caused by the change of a required property. According to the CPM/PDD theory, a synthesis step is needed to identify the affected properties and thus the characteristics which influence these properties and can lead to possible solutions to the EC-request (see subsection 4.2.3).

4.2.2 Relevance Classification

The step of relevance classification examines the properties identified before with regard to their relevance in the product or process context and describes the effects of an incorrect realisation of the elements listed. Here, it has to be thought of what kind of property is considered (e.g. customer requirement, specified by law, technically necessary, technically desirable ...) and what its influences on the rest of the product or the environment is. To give an example, the non-compliance of a car’s property “exhaust emissions higher than EURO5 limit value” would prevent homologation of the car.

² A detailed description of the FMEA-method can be found in [4], [5] or [21]. For critical considerations of the FMEA see e.g. [6] or [22].

The results of the relevance classification are documented in column (2) of the CIRA form (“Property relevance”).

4.2.3 Solution Synthesis

The solution synthesis uses the CPM product model to find all characteristics that could be the base of a solution to the change request. The synthesised characteristics are listed in column (3) of the CIRA form (“Adjustable characteristics”).

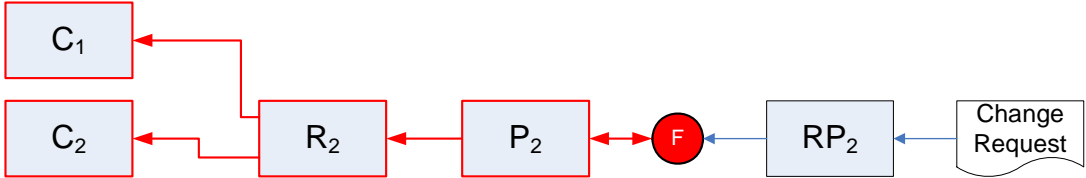

Figure 4: Solution synthesis – adjustable characteristics

In order to find a potential ECR-solution, the identified characteristics have to be examined in order to find out whether and how they can positively influence the change-requested property. That leads to the answer of the question, what a possible solution to the change request in the context of CPM/PDD is: in the case that the change request relates to the change of a required property, the solution to the change request is one or more characteristics plus the (qualitative) information how the characteristic(s) must be adjusted in order to positively influence the change-requested property, e.g. up-scaling of a shaft diameter.

The “Potential ECR-solutions” are documented in column (5) of the CIRA form.

4.2.4 Impact Analysis

As described above, the impact analysis looks for potential side effects caused by the change of the considered/synthesised characteristic which could lead to further changes (see Figure 5). So the result of this analysis step is a list of potential effects that have to be supervised in the case of changing that characteristic.

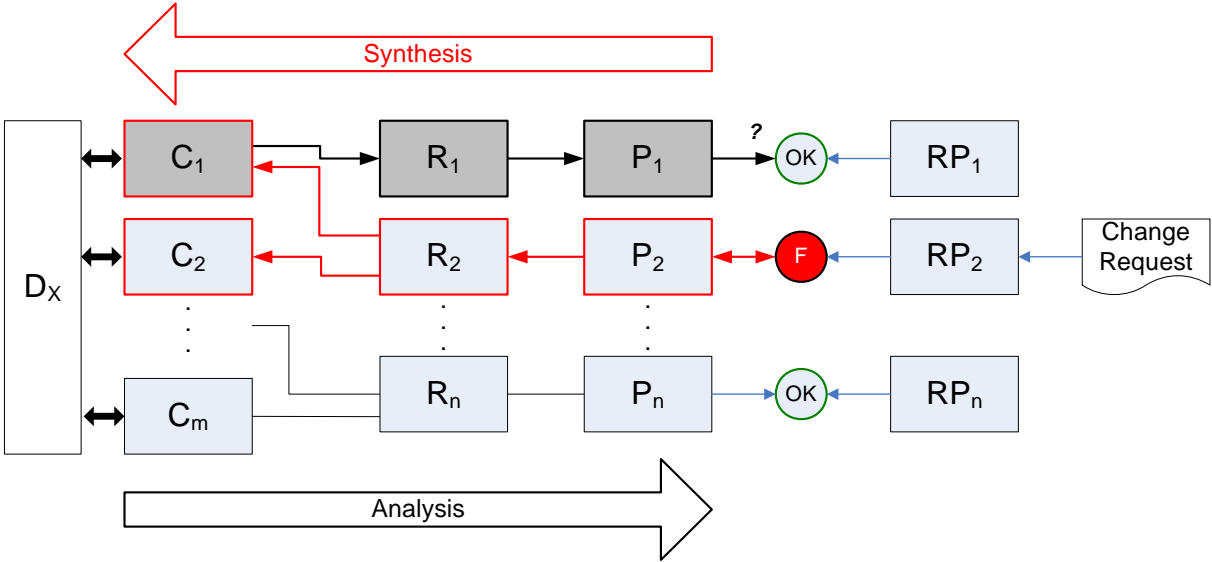

Figure 5: Impact analysis

Here, two considerations are needed. The first one analyses the influences of the adjustment on other properties. The second consideration looks at the dependencies between the characteristics and analyses whether other characteristics are (directly) affected by the change and whether there are (indirect) changes to other properties. For example the change of the outer shaft diameter causes directly the equal change of the inner hub diameter. On the other hand, the change of the shaft material has not to cause the change of the hub material as long as the material pairing matches.

The results of this phase are described in the columns (5, properties) and (6, characteristics) of the form.

4.2.5 Risk Evaluation

The step of risk evaluation is subdivided in,

- first, the evaluation of the significance (S) of the affected property in the context of the product, process or environment;
- second, the evaluation of the likelihood of the chances of success (C) of the potential ECR-solution;
- third, the evaluation of the change-impacts, i.e. the likelihood of further changes (I).

The evaluation of the significance (S) is based on the step of relevance classification described in subsection 4.2.2. To assess the chances of success (C), every potential ECR-solution is analysed with regard to its success prospects. This corresponds to an estimation of the quantity of required changes to the characteristic(s) identified. This evaluation relies to a big part on the experience of the designer (implicit knowledge). The likelihood of further changes (I) can be taken from the CPM product structure.

In allusion to the FMEA, each of the three indexes “S”, “C” and “I” is assessed with numbers from 1 to 10. Thereby, the assessment “1” stands for the best possibility with the lowest risk, the highest chance of success or the fewest impacts. In contrast, the number of “10” denotes the worst possibilities, i.e. the highest risk, the lowest probability of success or the least favourable (side) impacts. Finally, the three indexes “S”, “C” and “I” are multiplied. The result of the multiplication is the so called change classification number (CCN) while serves to support the selection of the best solution (lowest CCN) and in case of the comparison of several change requests it is a mean of decision making for the question “Which change realising first?”.

The results of the risk evaluation are documented in the columns (7)-(10) of the CIRA form.

4.2.6 Safeguarding

The last step of CIRA describes the measures which could safeguard the selected solution. This measure definition is based on the network-based description of the change effects described in the impacts list (columns (5) and (6) of the CIRA form).

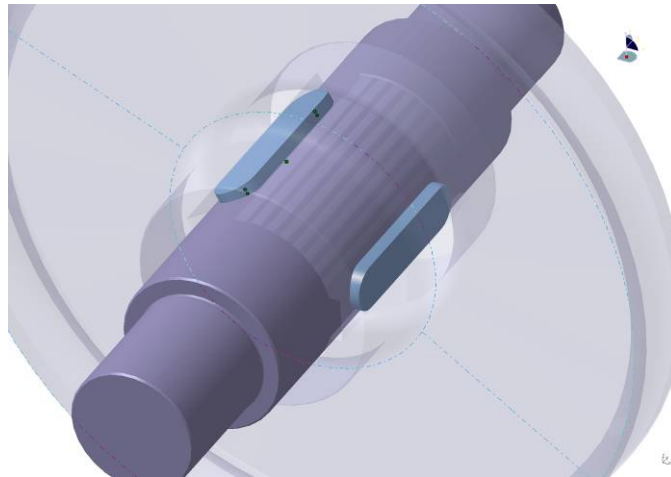

Figure 6: 3D-CAD-model of the shaft to collar connection

5 USE CASE

The example presented in this use case, is a shaft to collar connection which may be part of a pulley design. Any shaft to collar connection has to be able to transmit a certain torque which is the most relevant required property. Other properties (which, for reasons of simplicity, are not dealt with here) are manufacturing, assembly, strength, cost, etc. Figure 6 shows a key-connection (with two keys) as a well-known solution, which in our example represents the initial state of the engineering change process. The corresponding CPM/PDD-model is illustrated in Figure 7.-

The engineering change process (compare Figure 1) now starts with a change trigger. For this example the change trigger is the increase of the required transmissible torque (change of the most relevant required property). In our case this leads to the problem that – out of the four parts of the initial solution (2 parallel keys, 1 shaft, and 1 hub) – at least one is not capable to deal with the modified torque requirement. This can easily be deduced by the CPM/PDD model of the initial solution (Figure 7), but could, of course, also be analysed by more conventional methods.

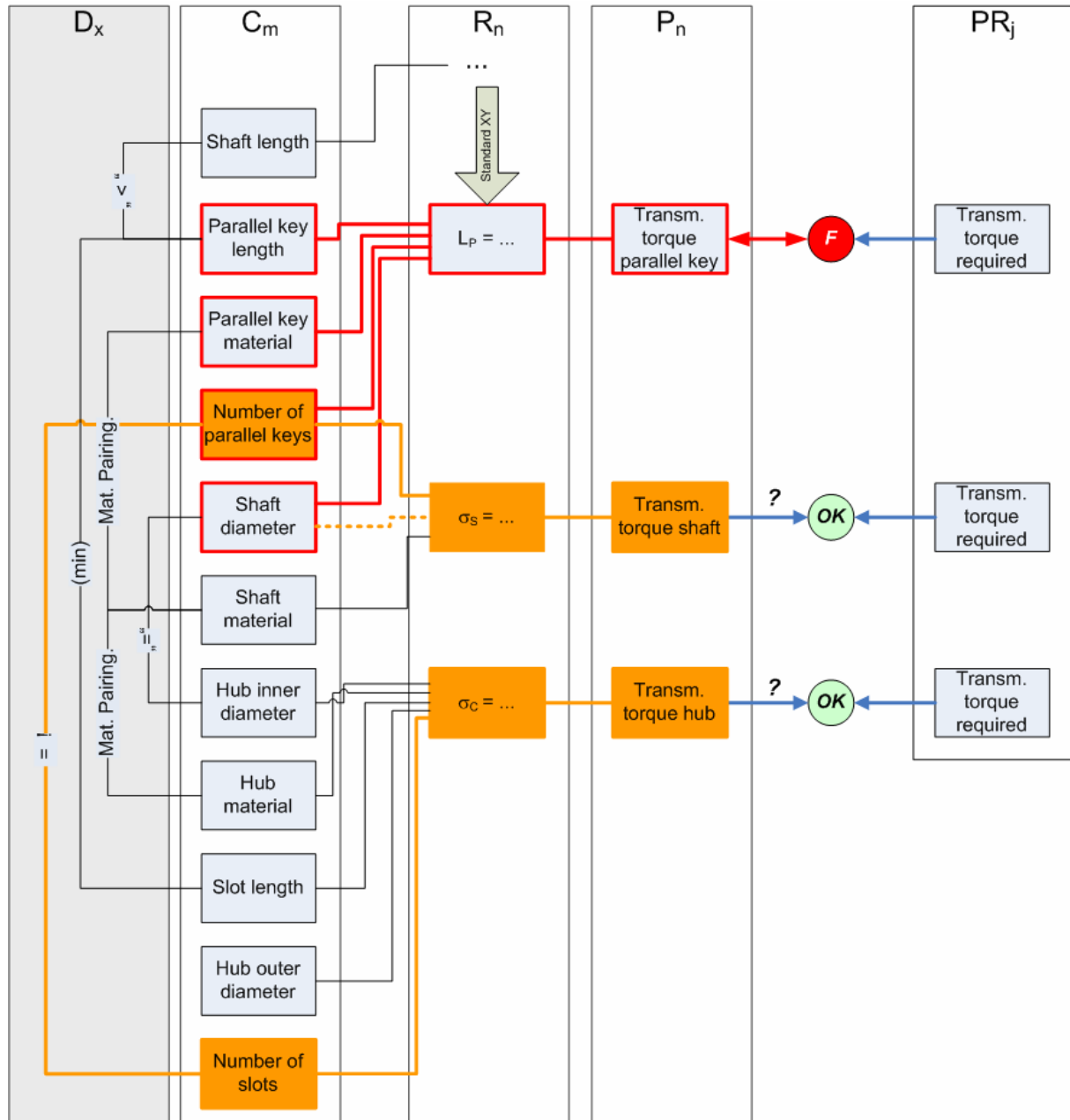

Figure 7: Impact analysis of CIRA (ECR-solution "shaft with splines")

The following synthesis examines which characteristics influence the critical property. The result of the synthesis-step is the identification of all characteristics the adjustment of which could be a possible solution to the EC-request. In this example the transmissible torque of the two parallel keys is the limiting property and gets influenced by the characteristics "parallel key length", "parallel key material", "number of parallel keys" and "shaft diameter". Thus, potential solutions to the EC-request are:

- Characteristic "parallel key length":
A longer parallel key can transmit a higher torque.

- Characteristic “parallel key material”:
A material (pairing) with a higher acceptable surface pressure can transmit a higher torque. The application of a material with a higher strength is also potential solution to the change problem.
- Characteristic “number of parallel keys”:
Instead of using two parallel keys, a shaft with splines can transmit a higher torque.
- Characteristic “shaft diameter”:
A bigger shaft diameter leads to lower circumferential forces and at the same time higher parallel keys which results in a higher transmissible torque.

After the description of the potential ECR-solutions the impacts of every solution must be analysed. As an example, the ECR-solution “shaft with splines” is presented here. The analysis of its impacts is depicted in Figure 7. The CPM/PDD product structure shows that the characteristic “number of parallel keys” is directly related to the property “transmissible torque by shaft” and, moreover, there exists a direct dependency to the characteristic “number of slots” in the hub that is related to the property “transmissible torque by hub”. Thus, the analysis of the CPM/PDD-model shows immediately that the ECR-solution “shaft with splines” has an impact on two other properties and one other characteristic. Furthermore, there is an indirect impact on a second characteristic that would, in case of a more detailed example, lead to further impacts. This characteristic is “shaft diameter”. A more detailed example would also include the external conditions “manufacturing” and “costs”.

Finally, the potential solution of the EC-request must be assessed. We have already seen that the relevance of the transmissible torque, a required property, is very high; it is, therefore, assessed with a relevance value $S = 8$ (out of 10 points). The next thing to consider is the probability of success of this solution (or, in general, *all* solutions) which corresponds with its easiness of realisation or its benefits in relation to expenses. In our case, the change from a key to a spline connection is obviously a solution with a relatively high probability of success; it is, therefore, graded with $C = 3$. Finally, the (side) impacts of the solution have to be assessed. In our little example the change from keys to splines has effects on two other properties (in this example even two other parts). So the impact of the change in relation to the whole product is quite considerable, so $I = 6$ is assigned. In total, this leads to a change classification number (CCN) of $S \times C \times I = 144$.

The rest of the analysis – also for a collection of other alternatives – is presented in the CIRA form depicted in Figure 8.

CHANGE IMPACT AND RISK ANALYSIS (CIRA)										
		Product: <u>Shaft to collar connection of a pulley</u>					Date: <u>21.01.2007</u>			
		Product-ID: <u>LKT2007_01</u>					Dep.: <u>UdS/LKT</u>			
EC-request: <u>Increase of the required transmissible torque</u>					ECR-No.: <u>ECR2007-01</u>					
As critically identified properties	Property relevance	Adjustable characteristics	Potential ECR-solution	Impact on other		S	C	I	Change classification number (CCN)	
				properties	characteristics					
Transmissible torque of parallel key (too small)	Lifting power is a customer requirement / Environment safety is endangered	Parallel key length	Increase the length of the parallel key	→	Shaft length	8	2	2	32	
				→	Slot length					
		Parallel key material	Selection of a material with a higher strength (steel)	→	Shaft material	8	5	1	40	
				→	Hub material					
		Number of parallel keys	Shaft with splines	→	Shaft diameter	8	3	6	144	
					→					Number of slots in hub
					←					Transmissible torque by hub
		Shaft diameter	Scale up of the shaft diameter	→	Parallel key length	8	3	5	120	
					→					Hub inner diameter
					←					Hub outer diameter

Figure 8: CIRA-result

As expected, the most promising ECR-solution of the EC-request is the increase of the length of the parallel key. The second best ECR-solution is the change of the parallel key material. Probably, the change of the parallel key material was not expected to be one of the best solutions for this examination. The reasons therefore are the simplifications made in the beginning of the case study. The characteristic “parallel key material” has in this case only indirect dependencies to the two other materials used for the connection. In case that all the materials are steel, the considered characteristic has no further impacts. Furthermore, the missing external conditions, e.g. manufacturing systems and cost aspects, lead to no further relations of the characteristic “parallel key material” and, thus, the assessment of the impact of the change is the best thinkable ($I = 1$). It is not said, whether the parallel key is a bought-in or a produced part, which may also lead to different impacts.

The safeguarding of the solution “increase of the parallel key length” is quite simple. The impact to supervise is that the parallel key length is still shorter than the shaft length and that the parallel key length fits to the slot length of the hub.

6 CRITICAL DISCUSSION, CONCLUSIONS AND FURTHER WORK

This contribution presents a new approach to synthesise solutions to an engineering change request, as well as to analyse and assess their risks and impacts. The Change Impact and Risk Analysis (CIRA) combines two methodologies: First, the CPM/PDD theory as a basis to describe the product, to synthesise the change solutions and to analyse their impacts; second, the FMEA-method as a mean to describe and quantify risks, to assess impacts and success probabilities of change solutions and to document the whole change process.

The approach shows some advantages and some weaknesses.

- The two main weak points are caused by use of the FMEA-like assessment method. Like its role model, the FMEA, CIRA is only able to analyse single solutions and not a combination of them and the analysis can not effectively be automated. Furthermore, all analysis and synthesis steps depend on the CPM/PDD product model. So a bad product model can lead to bad results in CIRA. Currently and as long no clear criteria are defined; the whole evaluation depends on experience and partly on the experience of the designers.
- But on the other hand the approach has a number of advantages that could make it a useful tool. The first advantage is that the integration of CPM/PDD product structure leads to an entire visualisation of the change impacts and is the fundament of a holistic consideration of changes. Second, the method uses the familiar FMEA-procedure and, third, the structure of the form allows an easy transfer to other quality-related documents, e.g. FMEA. The fourth advantage of the approach is that it is relatively easy expandable, e.g. to the consideration of costs, manufacturability or the analysis of manufacturing systems and so on.

To put it in a nutshell, the approach is effective and usable for the analysis and assessment of the risks of engineering changes of products or processes. That can lead to a reduction of failure costs and an improved reliability of products and processes and even to a decrease of product call-backs.

In order to improve and expand the approach further work is needed. The influence of further change triggers must be examined and the approach must be expanded to include the external conditions of the CPM/PDD-Theory, especially technical and microeconomic aspects. Furthermore, rules for the assessment of the relevance, the probability of success and the likelihood of further changes are needed and must be documented and a clear description of the types of dependencies is needed. To improve the performance of CIRA the CPM/PDD product structure should be connected to the CIRA form. This integration could also enable CIRA to analyse combinations of change solution. Moreover, in order to prove the usability of CIRA, further case studies and tests are needed, especially in the context, what happens, when newly defined requirements must be integrated.

REFERENCES

- [1] Adams H.W. Das Richtige richtig tun. *QZ-Qualität und Zuverlässigkeit*, 2005, No. 7, pp.32-33 (Carl Hanser Verlag, München)
- [2] PriceWaterhouseCoopers. *European Consumer Product Recalls More Than Double in 2005*, 2006 (<http://www.pwc.com>, published 21 February 2006)
- [3] Akao Y. *QFD – Quality Function Deployment*, 1992 (Verlag Moderne Industrie, Landsberg am Lesch)
- [4] VDI-Richtlinie 2247 *Qualitätsmanagement in der Produktentwicklung*, Entwurf, 1994 (Beuth Verlag, Berlin)
- [5] DIN-Norm 25448 *Ausfalleffektanalyse*, 1990 (Beuth Verlag, Berlin)
- [6] Breiing A.J. and Kunz A.M. Critical Consideration and Improvement of the FMEA. *Proceedings of the TMCE 2002*, Wuhan (China), April 2002
- [7] Eckert C., Clarkson P.J. and Zanker W. Change and Customisation in complex Engineering Domains. *Research in Engineering Design*, 2004, 15 (Springer Verlag, London)
- [8] Pulm U. *Eine systemtheoretische Betrachtung der Produktentwicklung*, 2004 (Dissertation, TU München)
- [9] Clarkson J. and Eckert C. *Design process improvement – A review of current practice*, 2005 (Springer Verlag, London)
- [10] Zentes J., Swoboda B. and Morschett D. *Internationales Wertschöpfungsmanagement*, 2004 (Verlag Vahlen, München)
- [11] Riviere A., Féru F. and Tollenaere M. Controlling Product related Engineering Changes in the Aircraft Industry *Proceedings of the 14th International Conference on Engineering Design, ICED '03, DS 31*, Stockholm, 2003, Paper No. 1230 (Full Paper, CD-Rom, The Design Society & the Royal Institute of Technology, Stockholm)
- [12] Krüger W. Wandel, Management des (ChangeManagement). *Handelsblatt Wirtschaftslexikon – Das Wissen der Betriebswirtschaftslehre*, 2006 (Verlag Schäfer Poeschl, Stuttgart)
- [13] Gries B., Gericke K. and Blessing L. How Companies Learn from Design Flaws: Results from an Empirical Study of the German Manufacturing Industry. *Proceedings of the 15th International Conference on Engineering Design, ICED '05, DS 35*, Melbourne, 2005, pp. 538 (Executive Summary), Paper No. 195.49 (Full Paper, CD-Rom, The Design Society)
- [14] Gries B. and Blessing L. Design Flaws: Flaws by Design?. *Proceedings of the 9th International Design Conference 2006 (Design 2006), DS36*, Dubrovnik, 2006, pp. 1451-1458 (Faculty of Mechanical Engineering and Naval Architecture, University of Zagreb, The Design Society)
- [15] Deubel T., Zenner C., Bley H. and Weber, C. Adaptation of a new Design Method for the Requirement-Driven Planning of Manufacturing Systems. *The 16th CIRP International Design Seminar: Design & Innovation for a Sustainable Society*, Kananaskis (Canada), June 2006, Paper No. 10061, pp.-534 (Full Paper, CD-ROM, published by P. Gu, D. Xue, A. Ramirez-Serrano, S. Park, & D. Fletcher)
- [16] Deubel T., Steinbach M. and Weber C. Requirement- and Cost-Driven Product Development Process. *Proceedings of the 15th International Conference on Engineering Design, ICED '05, DS 35*, Melbourne, 2005, pp.166-167 (Executive Summary), Paper No. 357.46 (Full Paper, CD-Rom, The Design Society)
- [17] Weber C. CPM/PDD – An Extended Theoretical Approach to Modelling Products and Products Development Processes. *Proceedings of the 2nd German-Israeli Symposium on Advances in Methods and Systems for Development of Products and Processes*, TU Berlin, 2005, pp.159-179 (Fraunhofer-IRB-Verlag, Stuttgart)
- [18] Weber C. and Deubel T. New Theory-Based Concepts for PDM and PLM. *Proceedings of the 14th International Conference on Engineering Design, ICED '03, DS 31*, Stockholm, 2003, pp.429-430 (Executive Summary), Paper No. 1468 (Full Paper, CD-Rom, The Design Society & the Royal Institute of Technology, Stockholm)
- [19] Weber C., Werner H. and Deubel T. A Different View on PDM and its Future Potentials. *Journal of Engineering Design*, 2003, 14(4), pp.447-464
- [20] Burr H., Deubel T., Vielhaber M., Haasis S. and Weber C. IT-Tools for Engineering and Production Planning in an international Automotive Company: Challenges and Concepts. *Proceedings of the 36th CIRP International Seminar on Manufacturing Systems*, 2003, pp.73-80 (Universität des Saarlandes)

- [21] Tietjen T. and Müller D.H. *FMEA-Praxis*, 2003 (Hanser Verlag, München)
- [22] Köhler C., Träger G. and Czenkusch C. Vom Risiko zum Restrisiko – Modifizierte FMEA-Auswertung verbessert Risikomanagement. *QZ-Qualität und Zuverlässigkeit*, 2006, No.10, pp.45-49 (Carl Hanser Verlag, München)

Contact:

Dipl.-Ing. Christian Köhler
Saarland University, Institute of Engineering Design/CAD
PO Box 15 11 50
D-66041 Saarbrücken, Germany
Phone +49 (0) 681 / 302 - 58303
Fax +49 (0) 681 / 302 - 4858
e-mail koehler@cad.uni-saarland.de
URL www.cad.uni-saarland.de