

TOWARDS A PRODUCT STRUCTURE FOR BRIDGING INDUSTRIAL DESIGN AND ENGINEERING DESIGN ISSUES.

Peter Schachinger, Petter Bergman and Kalle Brunö

Keywords: geometric representation, visualization, product structure, industrial design engineering, virtual reality

1 Introduction

In examining a consumer product it is hard to distinguish which parts of it are engineering-related and which are industrial design-related, since these aspects are tightly integrated. Despite this fact, today's industrial organizations and design tools have created different areas of knowledge often carried by separate individuals. We work towards knowledge integration and cooperation in developing a common product structure that must contain technical aspects as well as aesthetic, semiotic and ergonomic aspects. Moreover, communication success is highly dependent on the quality of spatial visualizations, since the end result is mostly physical with mixed aspects. This paper presents real-time interactive spatial visualizations (VR) that reflect a product structure, covering information that ranges from requirements, functions and systems to design solutions and product architecture. We exemplify visualization in requirements assessment for an automotive interior cockpit unit and for the layout of a ride-on lawn mower. Visualized structure and behavior are then related to the product model and so-called organ units.

2 Background and arguments

Visualization may improve product development that involves a large amount of people with different tasks and expectations on the end result. Misunderstandings can occur in spite of good written and oral communication, since lack of visualization most often results in non-matching mental pictures between individuals. Moreover, visualization may increase product awareness in early stages and can help to motivate individuals if correctly used.

Information visualization aims at visualizing abstract data that may not have a natural visual representation. A *descriptive* visualization represents a phenomenon that is already known although it has to be communicated in a good manner, for promoting a certain solution alternative or describing an assembly sequence. *Analytical* visualization aims at increasing the understanding of a process. The phenomenon is known although its presence has to be identified. A FEM solution, for example, indicates overloaded areas. *Explanatory* visualization helps in identifying patterns and relations not known beforehand.[1]

In today's CAD packages, FEM tools and Digital Mock-ups, there are increasing possibilities for attaching design information in addition to intended physical geometry. Some examples of industrial applications are:

Constraining geometry that represents forbidden areas. These could be movement envelopes of fan propellers, vibration spaces of engines, or simply a division between two different systems to be defined.

Ergonomic surfacing which includes ability-to-reach, field-of-sight, feet fitting, armrest, moving space etc. Surfaces are here basically defined as max, min and nominal.

CAD annotation functionality – where the user can add text directly in 3D – exists in most CAD software.

Stress, strain, temperature or surface fairness is illustrated by colored fields or three-dimensional graphs.

We believe that there is room for improvement when considering recent years' progress with real-time graphics hardware, and also when looking at results achieved in areas such as Geographic Information Systems (GIS)[2]. The approach in this paper is to make use of existing interactive real-time visualization technology (VR) functionality. Today's CAD and VR packages include most possibilities, although they lock the user to one format. We choose to make use of open-source VR, despite the longer development time. Open Scene Graph has optimum real-time performance, up-to-date rendering, and work on simple workstations [3]. There are basically four areas of design means for the virtual space: geometry and clouds, coloring and materials, light and fog, text and symbols (bitmaps) in 3D and movement in predefined loops. These can then be changed over time and respond to action. The virtual space can also be connected to external programs/files and thereby other design means.

In this paper we refer to requirements as measurable statements that constrain and guide in solution space and design work. We focus on requirements used for defining intended product properties and for describing subsystem interaction. User requirements (UR) define user needs such as comfort, accessibility, aesthetics and ability-to-reach. System requirements (SR) define technical performance factors such as speed, load volume and tolerances.[4]

3 The modeling framework and method

Models can sort under four types – requirements, product definition, life cycle description and property models. These are logically related to synthesis, analysis and evaluation [5]. The product model in this work (in Figure 1) describes partial requirements (intended product behavior) and product definition (structure and behavior), and establishes a causal link between requirements set and solutions proposed. We have shown in earlier work how industrial design information can be included in such a model [6][7][8]. The characteristics of the model are described below:

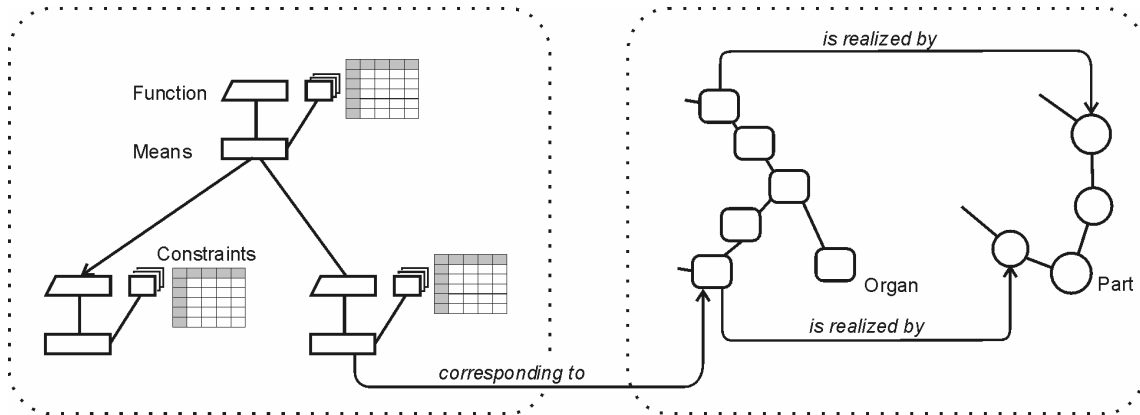

Figure 1. Schematic overview of the model.

Interactive and technical functionality. Interactive (i.e. ergonomic, semantic and syntactic) functions are used in addition to technical functionality, in order to better correspond to tasks jointly fulfilled by a user and technical system. By using interactive functions, industrial design-related properties can logically exist side by side with engineering properties in a product model.

Function-related requirements specification. Constraints/requirements are linked directly to each function defined, and are thereby transformed for specifying subsystems. User and system requirements are both used.

Function-oriented hierarchy. Functions are decomposed through means, i.e. solutions for those functions.

Means and organs. Organs are carriers of functions and are thereby one type of means for solving a function. Aesthetic organs (introduced by Warell) carry functions that create an effect in the mind of the user, while technical organs create an effect in a technical system.[9] Aesthetic organs enable industrial design characteristics to be modeled side by side in space with engineering characteristics.

Wirk surfaces and form entities. These are used in order to allocate function carriers (organs) in a geometric system representation, where wirk surfaces correspond to technical organs and form entities correspond to aesthetic organs.

Design solutions as information units. An organ unit is an information unit that contains knowledge about certain design behavior. Jensen has proposed attributes for its constitution, behavior and effects, relation to form, ownership etc. [10]. As regards configuration, a set of *configurable components* has been defined where one definite solution still can vary depending on the input parameters. This dramatically reduces the amount of information units needed [11]. Configurable components correspond to the term *generic components* that is also found in literature, and are part of *interference sets/components* that refer to placeholders [12].

Subsystem interaction. A subsystem may have to interact with other systems in order to fulfill its function – an *interacts with (iw)* relation. Moreover, a system can influence other systems' ability to fulfill a function – an *is influenced by (iib)* relation.

Some of the issues above are selected in the case studies for 3D representation, depending on whether they are relevant to major decisions taken in design and on what information these

are based upon. Also, the issues' potential for being represented in 3D has an effect on the selection. Text data and bitmaps presented with virtual objects, data affecting virtual object properties (form, color, scale, movement etc.), files and product data objects linked with virtual objects are VR functionalities of interest for this work. CAD files have here been brought into a surface modeling tool and then exported to the VR environment.

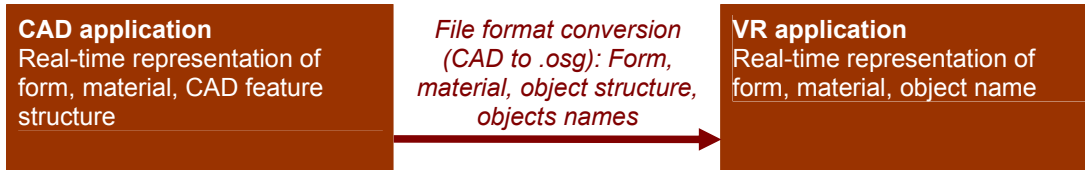

Figure 2. Export procedure

The representation and product model correspond to needs elicited from literature and studies performed mainly in the automotive industry. Logical verification is performed through the case study presented in this paper, comparison to industrial procedures and models together with continuous discussion with professionals.



4 Case study of Ride-on lawn mower: An architectual layout

Architectural (spatial) layout has a major effect on how successful the integration of engineering and industrial design aspects will be, since it affects the proportions and choice of materials for the carrying structure. Here we focus on the layout activities for a new type of lawn mower to be developed. Work has been performed by fourth-year students closely connected with a lawn mower company, performing a project parallel to a company in-house project. Prior to the layout activities, the design task was redefined, and concepts for alternative design languages and technical design principles for subsystems were developed and decided upon. The design component layout of the existing product served here as an input, but was not affected at this stage since ideas for subsystems were in focus without considering overall layout.

4.1 Case input

When the case study starts, one concept has been selected. One sub-solution has been selected for each technical function *power source (combustion 10.5 hp)*, *traction (in front)*, *steering (in rear)* and *frame (stamped)*. No layout activities have been performed at this stage, since none of the solution alternatives have been estimated to possess extraordinary space. Also, there are three proposals of design languages - integrated, structural and innovative. These proposals also carry ideas of features to distinguish this product from others - a saddle seat, an integrated seat and foldable cutting deck for easy cleaning. A combination of the Integrated and Innovative design proposals has been selected and further developed.

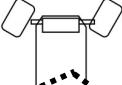
Table 1. Sub-solutions for the lawn mower.

Power	Traction	Steering	Frame	Cutting deck	Design language
Com 12 hp	Rear		I-type	Completely foldable	Integrated design
Com 10.5 hp	Front		Stamped	Stationary frame, foldable deck	Structural design
			Welded		Innovative design

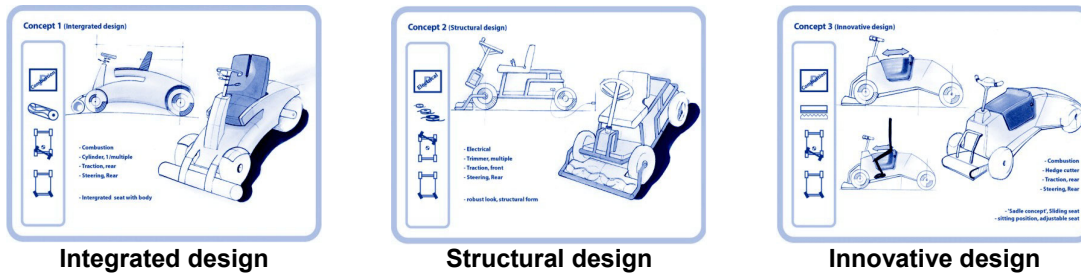

Figure 3. Input to the project

4.2 Visualization and product model

Task is re-defined at this stage: *Create a shorter vehicle with an easy-to-clean cutting deck.* The main idea is to put the seating above the power unit and make the cutting deck more compact in order to shorten the vehicle. Looking at the status in Figure 4, we see that the current package and design sketch do not match. No answers are given in the visualization regarding how design components can be re-positioned, resized, moved when in use or what underlying requirement there are. For the visualization, we have added element directly related to the design task as shown below. Each visual element is then related to intended product behavior (functions, requirements) and product definition (characteristics, properties).

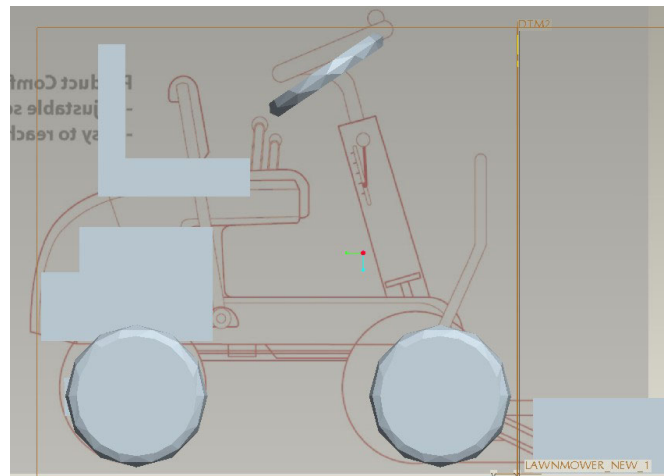

Figure 4. Industrial design view sketch and package status.

The critical issues for the design task are:

How should a package with a seating height less than X cm be accomplished? The optimum seat position and preferred height above the engine are critical dimensions in this case, shown in Figure 5. It is therefore important to show how these should be varied in direction and amount as done here. The "optimum seat position" requirement is then related to the ergonomic function "Support pelvis" while the "preferred height" requirement is an *iib* relation from the engine to the "Support pelvis" function.

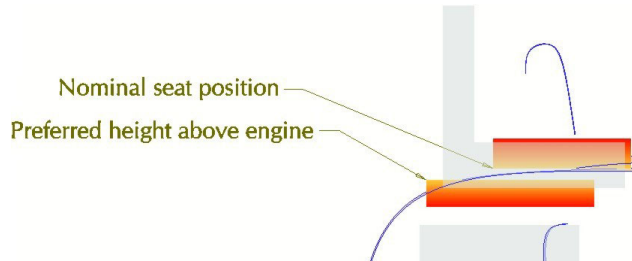

Figure 5. Critical dimensions of the seat.

What are the geometrical restrictions for a deck holder that enables easy rotating of deck for cleaning? The movement envelope of the deck is shown here in order to detect collisions. The envelope sorts under the function "Allow access for cleaning".

How short can the wheelbase be made without hazarding vehicle balance? Possible wheel positions are of interest with grading in the backward direction for vehicle balance and forward direction for compact measures (see Figure 6). The overall requirements "Full function at 20° roll and 30° tip" and "Max 1200 mm transport length (EUR pallet)" are related to the wheel organ unit in the model.

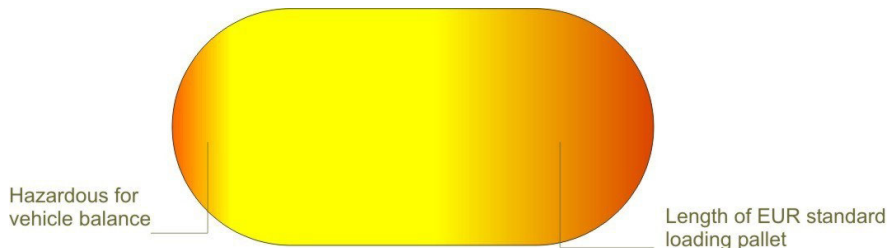
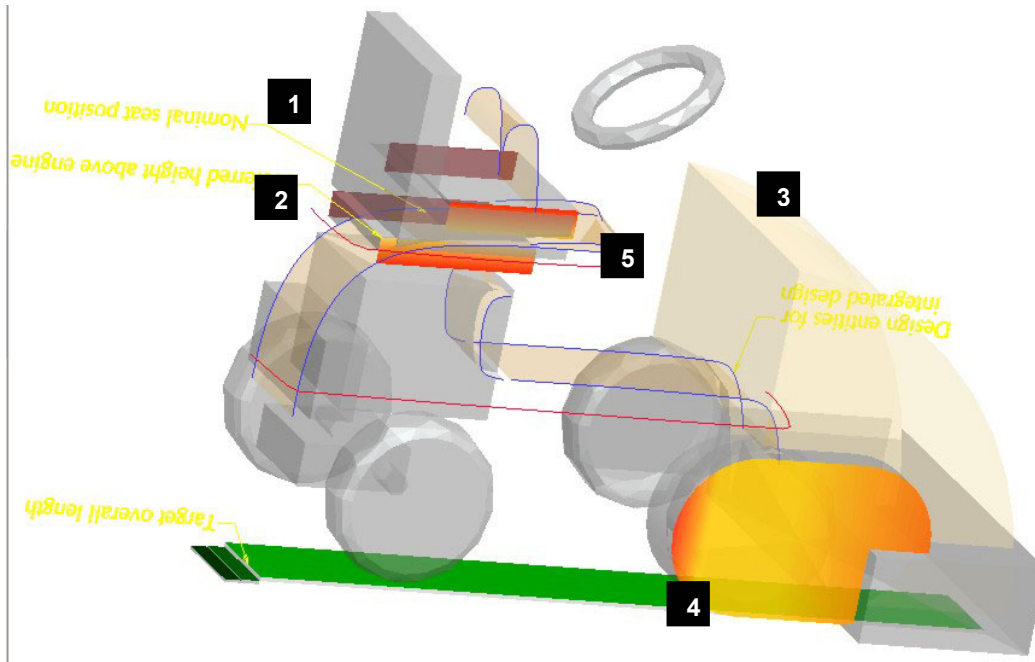

Figure 6. Position span of the front wheels.

How can the design proportions and form entities remain consistent while adapting to the package? In order to fit the package, proportions and form entities must change. These have to be evaluated on the gestalt as a whole. Therefore, before starting to model any surface geometry, characteristic form entities are "sketched" in the CAD modeler in order to identify conflicts and then adjusted in order to achieve correct proportions. Form entities such as tape surfaces and lines are sufficient in order to get a notion of the overall proportions and characteristic lines. A relation is made to the aesthetic organ "Integrated design language" which has its major appearance on the organ which carries the driver.



		Function	Organ unit
Cut grass	Move vehicle	Transform fuel to rotation	Combustion engine
		Transmit power to wheels	Strap, front traction 2
		Transform into translation	Wheels 4
		Enable speed adjustment	Strap mover <i>iib</i>
	Carry driver	Support feet	Board
		Support pelvis	Soft seat 1
		Support back	Soft back rest
		Enable adjustment	2
	Cut grass while moving	Identify model range	Integrated design <i>iib</i> 5
		Transform fuel to rotation	Combustion engine
		Transmit power to cutting	Strap
		Enable on/off cutting	Clutch
	Allow access for cleaning	Cover rotation 3	

Figure 7. VR model and function-means tree including form entities for industrial design (beige, blue and red lines), target seat height (graded) and overall length (green), cutting board envelope as well as allowed wheelbase (yellow graded).

5 Case study of automotive interior: Requirements visualization

5.1 Case input

Documentation from the development of an automotive cockpit module has served as an input for this case study. The module includes carrying structure, steering column, climate system, instrument panel, storage spaces, controls, airbags and other security systems. Components are developed and assembled as an integrated module in order to be able to use it in other products with small modifications. Almfelt et al. have performed an empirical study of the teamwork, with the aim of identifying and describing development, changes, deviations and compromises in requirements and their representations [13]. In the study, respondents noted insufficient relations between different requirement documents and interdependence between components. Handling of specific requirements (by different types of documents) worked well, although it was found difficult to follow up requirements. Some respondents were also bothered by a reduced overview of requirements due to increasing number of documents, ability to handle extra information, increased referencing, and misunderstanding of poorly written documents.

In this case study, we explore possibilities to improve context and meaning of requirements areas within the scope of a product model. Key requirement areas are used in the project work as an input for representation. Also, visualization is related to attributes for some organs. In the automotive project, requirements were continuously updated and the effects estimated, and summarized on one single paper sheet as shown below. This case study, however, focuses on "snapshots" of information from single occasions and does not consider changes over time.

5.2 Visualization of context and meaning of requirements

User requirement (UR): Increase crash performance -> System requirement (SR): Optimized and individual triggering of security systems. In order to increase crash performance, an individual triggering of the safety systems (airbags, belt restrainers etc.) is desired, so as to adapt to crash direction, number and weight of passengers etc. In this situation, a clear overview is needed of how systems should relate to different crash situations, meaning (1) whether and to what extent they should be executed and (2) how systems interact.

In the suggested visualization, the safety systems are visualized with the cockpit in order to give a complete view of the allocation of the requirement (see Figure 8). Systems include a three-dimensional relational model with symbols. Input signals such as direction, crash speed, passenger weight and use of belt are also visualized with the cockpit, in order to clarify what "Optimized and individual triggering" mean. A display shows the activated system for a specific crash situation. Input parameters involved in that specific crash situation are related to the display in order to complete the overview. The requirement type (Increased crash performance) is represented by a symbol in order for the observer to get an immediate notion of requirement origin. A similar method could be used for other requirements, making the observer aware of why each requirement exists.

Table 2. Treated airbag organ attributes and subsystem relations

Type	Subtype	What is visualized?
Structural	Kind of	<i>Wirk element shape and position</i>
Causal	Function	<i>Link to input parameters</i>
Class	Kind of	<i>Airbags show similar color/material</i>

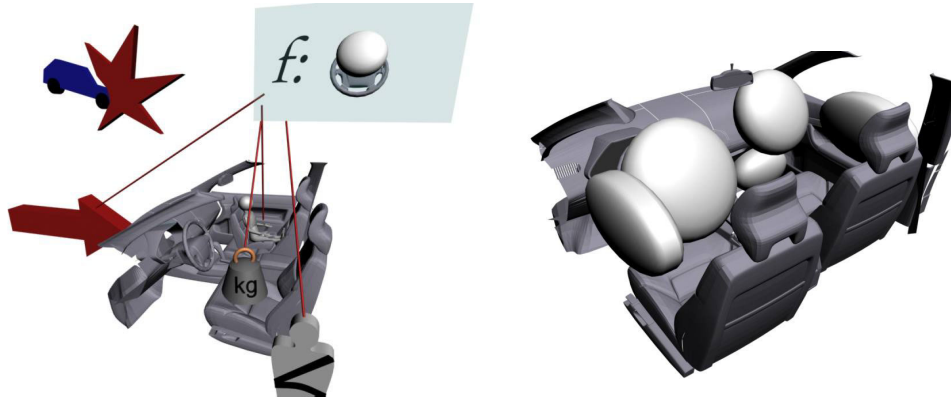

Figure 8. 3D relational model with symbols for crash direction, driver weight and the use of seat belts

UR: Clean compartment air -> SR: Reduced material emissions by 25%. Excessive material emission (i.e. chemicals from plastics and fibers from textiles) can result in thin films of dirt throughout the whole interior, and can also be smelly and hazardous.

By illustrating fogging properties of different materials, one could improve materials selection and arrangement of components. Figure 9 shows examples of fog and surface coloring determining type and size of emissions. A fog object corresponds to set requirements, while the surface coloring characterizes emission from single surfaces.

Table 3. Treated seat organ attributes

Type	Subtype	What is visualized?
Structural	Kind of	<i>Wirk element shape</i>
Behavior model	External behavior	<i>Activated in relation to a emission requirement</i>
	Physical effect	<i>Vapor and textile dust</i>
	Allocation assumption	<i>Placement of wirk elements</i>
Class	External class	<i>Color for each class</i>
Causal	Part	<i>Elements are laid over the part structure</i>

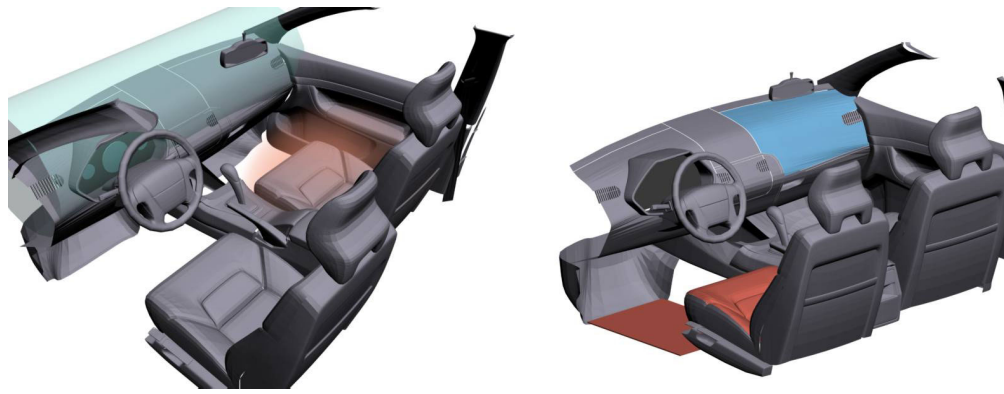

Figure 9. Material emissions represented as fog and surface coloring.

UR: Solidity and Law Regulation -> SR: Lowest frequency of resonance should be at least X Hz. Vibrations can harm components and could be perceived as unpleasant. Engine and wheels are main sources.

Colors here correspond to certain frequency intervals: either the main interval of a source or banned intervals for assemblies. Figure 10 shows that a certain frequency interval should be avoided or damped for the chair since it can be inconvenient or even harmful for humans. The wheel is the main contributor in this case.

Table 4. Treated relations

Type	What is visualized?
Is influenced by	Common colors mark the relations



Figure 10. Illustration of main causes of vibrations

UR: Increased crash performance -> SR: Steering wheel deformation. F_{max} . The wheel system (active and passive) should here decelerate the driver as fast as possible in a given deformation distance without exceeding the critical force. The passive system can be deformed in a given distance.

An animation loop in the virtual environment is suggested here in order to clarify the course of events (see Figure 11). Forces which act at different deformations are shown by arrows with varying transparency, accomplished by a displayed graph which synchronizes with the deformation of the steering column. It can be shown how the force affecting the driver is changed with different required deformation distances. Use of a seat belt highly affects the

behavior of the deceleration system and is therefore indicated with a seat belt symbol. The space where the steering wheel will move during the crash is not to be utilized by any design systems and is therefore illustrated by a yellow-black indication, since this color combination is commonly used for protected areas.

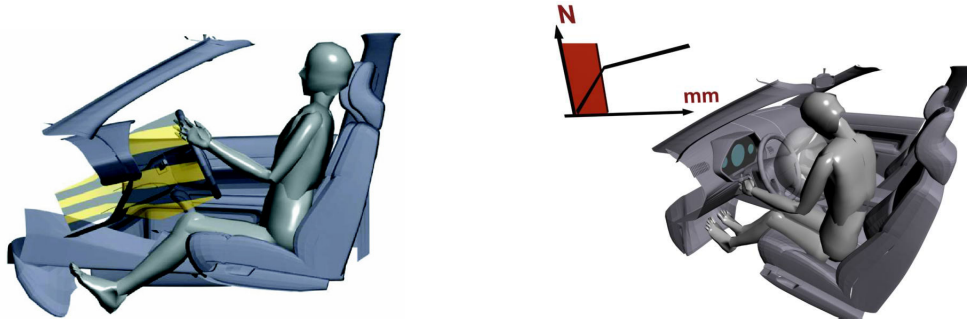

Figure 11. Protected deformation zone illustrated in a plane. Animation of crash sequence.

UR: Increase crash performance -> SR: Passive knee absorber X mm for the US market. Prepare package for an active system. It is important here to show the areas covered by active and passive protection and the interval of initial knee speed.

We suggest that colored fields in Figure 12 should show likelihood of impact position of the knees for a certain body size, so that the structure stiffness can be optimized and any conflicts with other functionality such as storage can be characterized.



Figure 12. Likelihood of impact position for the knees. Color density as a result of potential weight reduction.

UR: Environmental load and Cost -> SR: (1) Reusable or recyclable parts by y %. (2) Total weight reduction by x %. An overview is needed in this case to see where the most effective result can be achieved.

A spatial overview is suggested in Figure 12, where color density depends on *part weight multiplied by potential recyclability* for (1), and *absolute weight reduction per man-hour spent* for (2) above. Darker colors represent more potential, since these are perceived as being heavier. We suggest making the division into assemblies or individual parts in this case, where the solution is rather well defined.

6 Results

The current ambition of the research work as a whole is to cover several areas suggested here for visual spatial representation of a product model. The case studies in this paper has exemplified some of these areas (in Table 5.)

Table 5. Areas for visual representation.

	Auto interior	
	Lawn mower	
Design intention and constraints		
Communicative functions		
Treated: Intended product identity as part of the overall requirement definition.	X	
Not treated: Semantic functionality (descriptive, expressive)		
Intended technical functionality		
Treated: For layout: subsystem characteristics (temperature fields, movement	X	X
Not treated: characteristics: quick, viz. to see differences in key properties.		
Variation		
Treated: Variation and the effect on product usability (wheel positions)	X	
Not treated: Variation and the effect on market success, feasibility and cost		
Uncertainties		
Not treated: Requirement importance and risk-of-failure		
Meta data		
Treated: Requirements' type (coloring, symbols and three-dimensional relations),		X
Not treated: Requirements' life-cycle phase origin, stakeholders, status,		
Design solutions, product architecture		
Aesthetics and ergonomics		
Treated: form entities for product identity	X	
Not treated: ergonomic properties		
Properties		
Treated: characteristics and resulting properties for sub-systems	X	X
Not treated: Rapidly exploring sub-system alternatives and their impact on the		
Physical layout and package		
Treated: fit and interference	X	X
Not treated: Alternative solutions dimensions		
Modular aspects		
Treated: interdependencies with other subsystems	X	
Not treated: Identifying similar design components/modules/functional carriers		
Meta data		
Not treated: Confirmation of completed parts – status, spatial priority, configuration		

7 Discussion

Surfaces are far from the only means to allocate functionality and other properties. Elements of form, particle fields, color and pattern are used here as building blocks for locating properties and characteristics, in the same way that functions are located through work elements. We have furthermore connected visual elements directly to organ units in this case study. It should be questioned whether behavior matches an organ structure fairly well, or whether behavior should be allocated as a structure separate from the organ structure. However, connecting towards organs puts more focus on functionality and overall design intent.

The function-means model suits the first case study, where product complexity is fairly low (compared to the above) and the layout is the main issue. Connections between the functional hierarchy and physical layout is logic and foreseeable. Required overall properties can therefore be logically broken down and related to three-dimensional space. In the second case study however, do not have a product structure that is based on function hierarchy. The vehicle is divided into modules (cockpit, chair, roof etc.) that embrace several functions each (decelerate passenger, store accessories, maintain interior temperature). Relations between required properties and functional units are most commonly treated when it comes to assessment and fulfillment of product purpose, since most functionality on this level is settled before the engineering project starts. This also has the result that no interdependence between functional units is documented; functional units are grouped depending on their physical appearance in the vehicle, and not on overall functional fulfillment. An overview of requirements, or the functional structure (organs), is not visible through existing documents, and the aim in this case has not been to visualize one, even though that was a request from the empirical study. It is important to realize that the system complexity of this type of product, in combination with manufacturing volume and legal regulations among other things, disqualifies new design in architectural layout and functional structure. Ambitions to provide a product structure for the whole vehicle based on the function-means tree are therefore unnecessary in this case. However, this is a different issue when it comes to providing greater design freedom in subsystems, feasible concept vehicles and major technology changes. A direct requirement-functional unit structure such as the above would here be too concretized and block the solution space.

8 Conclusions

We have shown through case examples that illustration serves as clarification of requirements and system properties. Elements used for visualization have been related to a product model that has been presented in earlier work. Several examples have been shown which illustrate the link between product data and geometric representations. These examples have been defined both in relation to a hierarchic function-means structure (in the Lawn mower case) and to organ units (in the Automotive interior case). We have also identified areas for visual spatial representation and categorized the examples according to these. Further work is and more case studies are needed in order to explore potential areas, categorize visualization types and validate the visualizations done. A restriction to certain visualization areas, products or property areas might be necessary.

References

- [1] Petterson R., "Bild och form för informationsdesign", Lund, Sweden, Studentlitteratur, 2004
- [2] ESRI, gis.esri.com, Access date 2005-03-15
- [3] Open Scene Graph, www.openscenegraph.org, Access date 2005-03-10
- [4] Stevens R., Jackson K., Brook P., Arnold S. "Systems Engineering", Pearson Education, 1998.
- [5] Sutinen, Krister "Supporting Requirements Management by Requirements-Driven Product Modelling", Doctoral thesis, Product and Production Development, Chalmers University of Technology, ISBN 91-7291-481-5, 2004.
- [6] Schachinger, P. "Supporting Form Synthesis: Modeling Product Structure and Behavior in a Computerized Environment", Ph. D. thesis, Product and Production Development, Chalmers, Göteborg, 2002.
- [7] Schachinger, P. "Decomposing Industrial Design Requirements related to Form Synthesis in a Computer Environment", Proceedings of Tools and Methods in Competitive Engineering - TMCE'02, April 22-26, Wuhan, China, 2002.
- [8] Schachinger, P., "Industrial Design Engineering – Facilitating Communication of Product Properties using Web-based Virtual Reality", Proceedings of ICED'01, ISBN 1-86058-354-7, Glasgow, August 21-23
- [9] Warell, A. "Design Syntactics: A Functional Approach to Visual Product Form", Doctoral thesis, ISBN 91-7291-101-8, Product and Production Development, Engineering and Industrial Design, Chalmers University of Technology, Göteborg, Sweden, 2002.
- [10] Jensen, T. "Functional Modelling in a Design Support System – Contribution to a Designer's Workbench", Doctoral thesis, Department of Control and Engineering Design, Technical University of Denmark, IKS publication 99.44 A, ISBN 87-90130-20-0, Lyngby, 1999.
- [11] Claesson, A. and Gedell, S., "Product Description Using Configurable Components." Proceedings of ICED'03. International Conference on Engineering Design, Stockholm, Sweden, August 19-21, 2003.
- [12] D. H. Brown, "Fundamentals of Shared Product Structure", D. H. Brown Associates Inc., Port Chester, New York, USA, 2001.
- [13] Almfelt, L., Andersson, F., Nilsson, P., & Malmqvist, J. "Exploring Requirements Management in the Automotive Industry". Proceedings of ICED'03, International Conference on Engineering Design, Stockholm, Sweden, August 19-21, 2003.

For more information please contact:

Peter Schachinger, Chalmers University of Technology, SE-412 96 Göteborg, Sweden
Tel: +46-31-772 13 74, Fax: +46-31-772 58 58, E-mail: peter.schachinger@chalmers.se
URL: www.ppd.chalmers.se